



Automatic Variable Speed Booster System

Type UE-MONO (I)

APPLICATIONS

- Domestic water supply for villas, houses, schools, hotels, pent-houses, rest houses and buildings.
- Industrial water boosting.

FEATURES / BENEFITS

- **Constant pressure**
 - PID Controller with inverter able to adjust water pressure perfectly by variable speed control.
- **Energy saving**
 - Using of the inverter able to save energy.
- **No water hammering**
 - Preventing water hammer as speed is adjusted automatically to meet variable demand.
- **Fully tested & assembled unit**
 - Ensure trouble-free operation.
- **Stainless steel pump set used**
 - Hygienic and clean water assured.
- **EBARA TOTAL warranty on all components used**
 - More value for money.
- **Nationwide dealers representation**
 - After-sales service assurance.

SPECIFICATIONS

- Supply Voltage : 1 x 230 Vac \pm 10% (50Hz)
- Max liquid temperature : 90°C
- Installation : Indoor / Outdoor



Pump type : CDX



Pump type : Matrix

PERFORMANCE CURVE

**Pump type :
CDX**

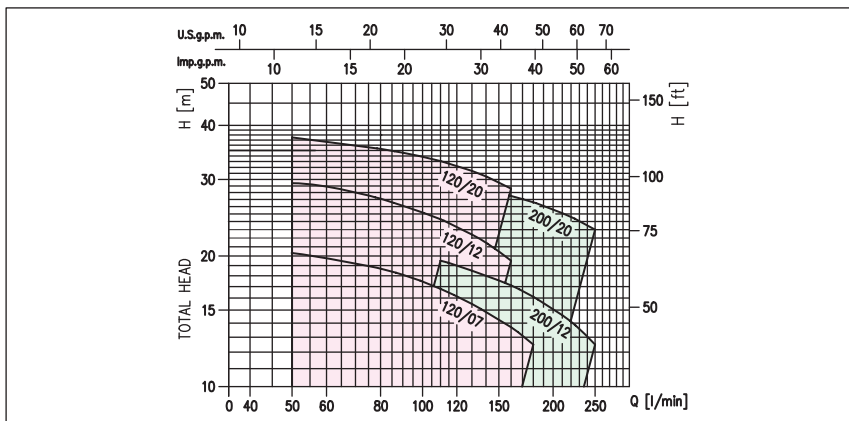

**Pump type :
MATRIX**

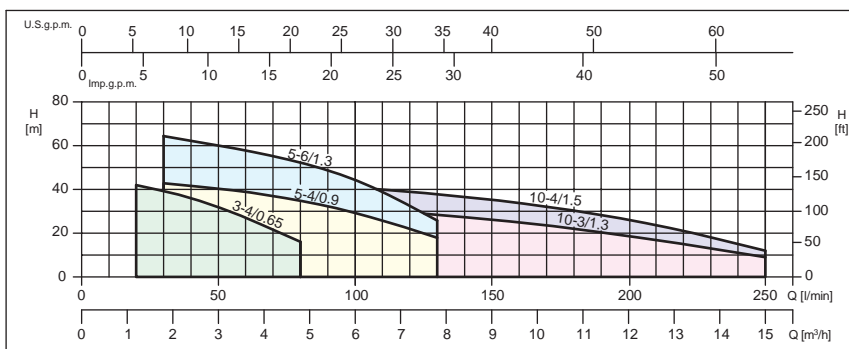

DIMENSIONS

Pump type : CDX

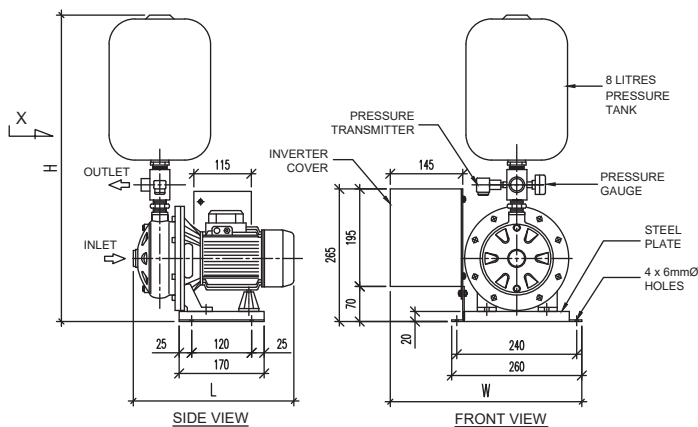

Model	Power (kw)	Dimension (mm)			Connection		Weight (kg)
		L	W	H	Suction (Ø)	Discharge (Ø)	
CDX 120/07	0.55	320	380	625	1 1/4"	1"	14.1
CDX 120/12	0.9	332	380	625	1 1/4"	1"	16.4
CDX 120/20	1.5	371.5	380	645	1 1/4"	1"	22.1
CDX 200/12	0.9	332	380	625	1 1/2"	1"	16.2
CDX 200/20	1.5	371.5	380	625	1 1/2"	1"	21

Pump type : MATRIX

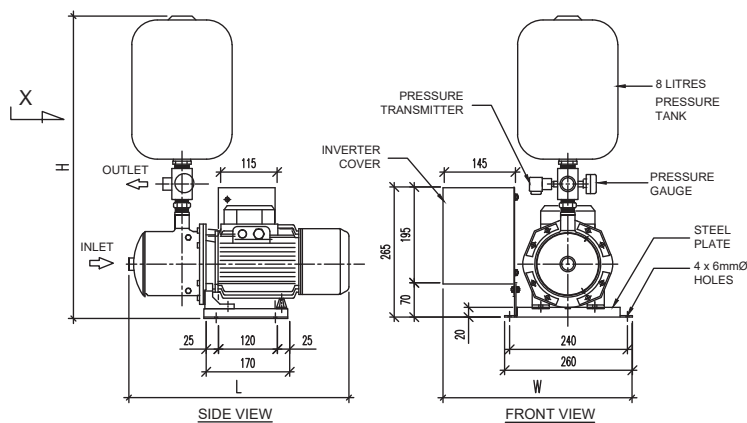

Model	Power (kw)	Dimension (mm)			Connection		Weight (kg)
		L	W	H	Suction (Ø)	Discharge (Ø)	
MATRIX 3-4T/0.65	0.65	384	380	580	1"	1"	15.9
MATRIX 5-4T/0.9	0.9	396	380	580	1 1/4"	1"	16.4
MATRIX 5-6T/1.3	1.3	494	380	580	1 1/4"	1"	21.1
MATRIX 10.3T/1.3	1.3	441	380	580	1 1/2"	1"	18.5
MATRIX 10.4T/1.5	1.5	471.5	380	580	1 1/2"	1"	22.2

* Dimensional details are provided for reference only.

* All specifications are subject to change without prior notice.



EBARA Pumps Malaysia Sdn Bhd
 6, Jalan TP3, UEP Subang Jaya Industrial Park,
 47620 Subang Jaya, Selangor, Malaysia.
 Tel : 03-8023 6622 Fax : 03-8023 9355
 Email : sales.epm@ebara.com
 Website : www.ebara.com.my



Authorised dealer: