



EBARA AutoMatic PressControl

Type MHS AM-PCT

OPERATIVE FEATURES

- Quiet operation, thanks to EBARA design that makes this possible.
- Starts and stops the pump when the tap is opened or closed.
- Maintain pressure at a constant level during operation, eliminating hot/cold shower fluctuations.
- Shuts off the pump if loss of prime or dry-running occurs.
- Self-priming operation is permissible.
- Ensure your pump system to operate at optimum performance.

EBARA MHS AM-PCT

EBARA MHS AM-PCT is an Automatic booster pump system consisting of Ebara quality MHS pump fitted with Ebara PC controller and 8 lit pressure tank.

MHS AM-PCT is an intelligent system combination of hydraulic and electronic know-how. PC Controller monitors the pump start and stop automatically according to demand and protects the pump from dry running. The integrally fitted pneumatic tank ensures smooth flow from faucets, reduces the number of start/stop which eliminates pulsations and water hammering.

Most importantly, **EBARA MHS BOOSTER** type MHS AM-PCT is absolutely quiet, durable and simple to install.



= 2850 min⁻¹

PUMP MODEL	P2		*Application	Q m ³ /h l/min	0	0.6	1.2	1.8	2.4	3.0	3.6	4.2	4.8	5.4	6.0	7.2	7.8	8.7
	KW	HP			0	10	20	30	40	50	60	70	80	90	100	120	130	145
MHS60-3M AM-PCT	0.5	0.65		H (m)	30	29	26	22	17	12	7	-	-	-	-	-	-	-
MHS60-4M AM-PCT	0.7	0.95			40	39	35	31	25	18	10	-	-	-	-	-	-	-
MHS60-5M AM-PCT	0.85	1.15			50	48	44	38	31	24	15	-	-	-	-	-	-	-
MHS90-4M AM-PCT	0.85	1.15			43	42	41	39	36	33	29	24	17	9	-	-	-	-
MHS120-4M AM-PCT	1.0	1.3			48	47	46	44	42	39	35	31	27	25	17	6	-	-
MHS145-4M AM-PCT	1.3	1.65			50	49	48	47	45	43	41	38	35	32	28	18	14	5

Q=FLOW RATE H=TOTAL DYNAMIC HEAD IN METERS

*For guidance only

DIMENSION

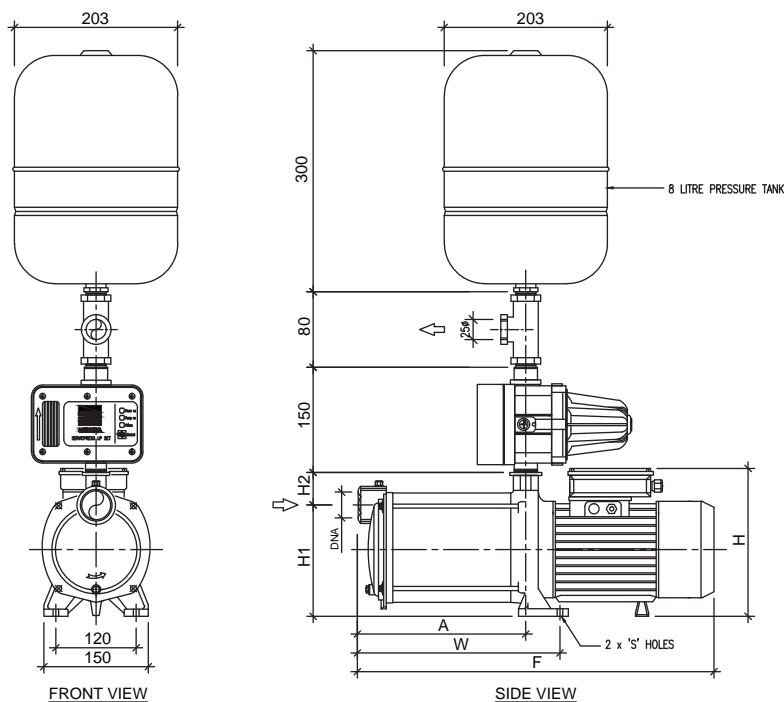

Pumps Type	kW	Dimensions (mm)							Suction	Discharge
		A	F	H	H1	H2	W	S		
Single Phase	P2	1~							DNA	D2
MHS60-3M AM-PCT	0.5	170.5	359	192	122	32.5	188.5	10	1" NPT	1" NPT
MHS60-4M AM-PCT	0.7	194.5	407.5	204	126	36.5	214.5	10	1" NPT	1" NPT
MHS60-5M AM-PCT	0.85	219	432	204	126	36.5	239	10	1" NPT	1" NPT
MHS90-4M AM-PCT	0.85	194.5	407.5	204	126	36.5	214.5	10	1" NPT	1" NPT
MHS120-4M AM-PCT	1.0	194.5	407.5	204	126	36.5	214.5	10	1 ¼" NPT	1" NPT
MHS145-4M AM-PCT	1.3	194.5	437.5	204	126	36.5	214.5	10	1 ¼" NPT	1" NPT

* Dimensional details are provided for reference only.

* All specifications are subject to change without prior notice.



EBARA Pumps Malaysia Sdn Bhd
 6, Jalan TP3, UEP Subang Jaya Industrial Park,
 47620 Subang Jaya, Selangor, Malaysia.
 Tel : 03-8023 6622 Fax : 03-8023 9355
 Email : sales.epm@ebara.com
 Website : www.ebara.com.my



Authorised dealer: