



Automatic Variable Speed Booster Unit

Type JET-E (P2) MATRIX

APPLICATIONS

- Domestic water supply for villas, houses, schools, hotels, pent-houses, rest houses and buildings
- Industrial water boosting.

FEATURES

- **Constant pressure**
 - PID Controller with inverter able to adjust water pressure perfectly by variable speed control.
- **Energy saving**
 - Using of the inverter able to save energy.
- **No water hammering**
 - Preventing water hammer as speed is adjusted automatically to meet variable demand.
- **Fully tested & assembled unit**
 - Ensure trouble-free operation.
- **Stainless steel pump set used**
 - Hygienic and clean water assured.
- **EBARA TOTAL warranty on all components used**
 - More value for money.
- **Nationwide dealers representation**
 - After-sales service assurance.



PERFORMANCE CHART

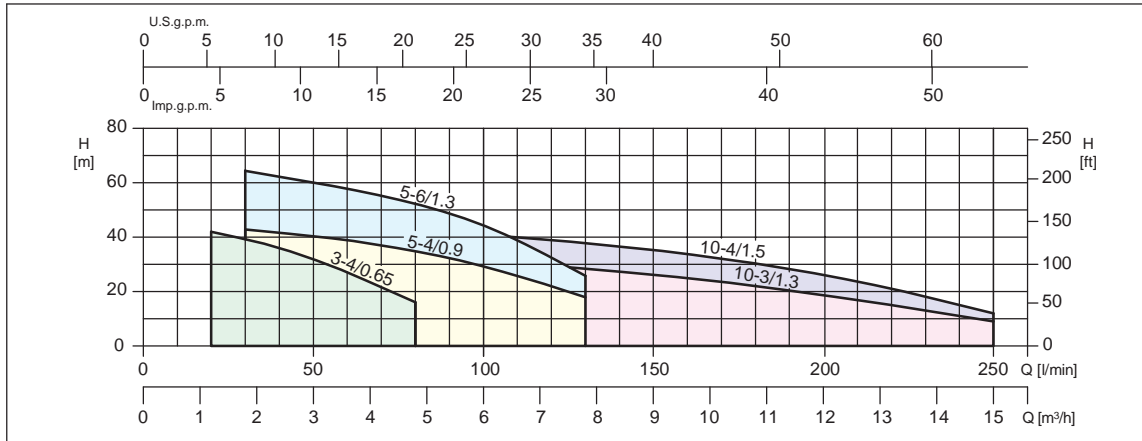

Pump type	Power		Q=Capacity													
	kW	HP	l/min m³/h	0	20	30	45	60	80	100	130	160	200	250		
Single-phase 1/50/230V				0	1.2	1.8	2.7	3.6	4.8	6	7.8	9.6	12	15		
				H=Total head												
JET-E (P2) MATRIX 3-4(.)0.65	0.65	0.9	45	42	39.1	34	27.2	16	-	-	-	-	-	-		
JET-E (P2) MATRIX 5-4(.)0.9	0.9	1.2	46	-	43	41	38.6	34.7	29.4	17.6	-	-	-	-		
JET-E (P2) MATRIX 5-6(.)1.3	1.3	1.8	69	-	64.5	61.5	58	52	44	26.4	-	-	-	-		
JET-E (P2) MATRIX 10-3(.)1.3	1.3	1.8	36	-	-	-	33.3	32.1	30.9	28.6	25.5	19.3	8.7	-		
JET-E (P2) MATRIX 10-4(.)1.5	1.5	2	48	-	-	-	44.5	43	41	38.1	34	25.7	11.6	-		

DIMENSION

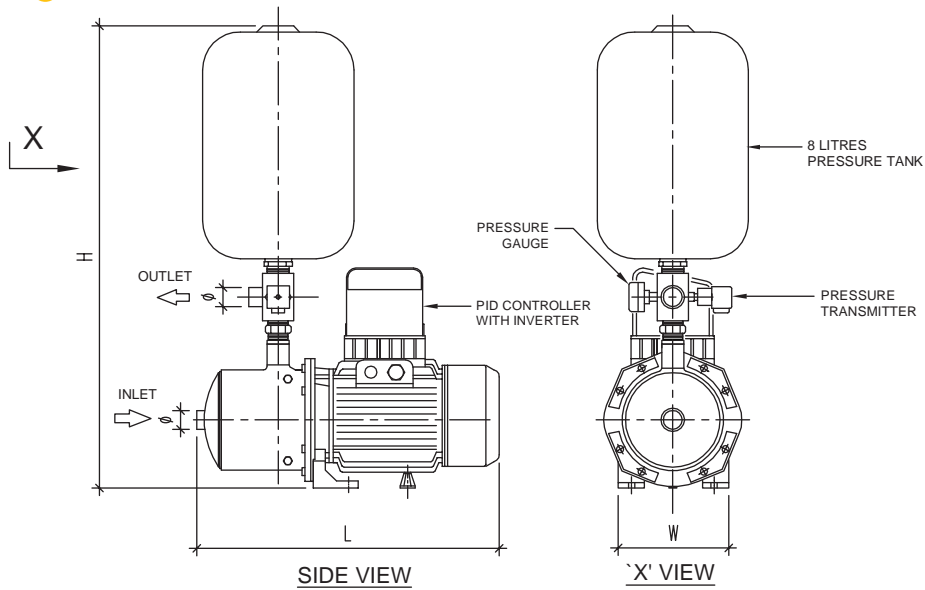

MODEL	Power (kw)	Dimension (mm)			Connection		Weight (kg)
		L	W	H	Suction (Ø)	Discharge (Ø)	
JET-E (P2) MATRIX 3-4T/0.65	0.65	384	165	560	1"	1"	11.6
JET-E (P2) MATRIX 5-4T/0.90	0.90	384	165	560	1"1/4	1"	13.3
JET-E (P2) MATRIX 5-6T/1.30	1.30	469	165	560	1"1/4	1"	16.7
JET-E (P2) MATRIX 10-3T/1.30	1.30	416	165	560	1"1/2	1"1/4	15.2
JET-E (P2) MATRIX 10-4T/1.50	1.50	446	165	560	1"1/2	1"1/4	16.7

* Dimensional details are provided for reference only.
 * All specifications are subject to change without prior notice.



EBARA Pumps Malaysia Sdn Bhd
 6, Jalan TP3, UEP Subang Jaya Industrial Park,
 47620 Subang Jaya, Selangor, Malaysia.
 Tel : 03-8023 6622 Fax : 03-8023 9355
 Email : sales.epm@ebara.com
 Website : www.ebara.com.my



Authorised dealer: