



Submersible Pump

Type DQA

APPLICATIONS

- General purpose pumping
- Handling drain water
- Emptying pits and discharge into sewers
- For automatic dirty water pumping.

SPECIFICATIONS

- Maximum liquid temperature : 40°C
- Maximum immersion : 4 m
- Liquid PH: 5~9
- Maximum passage of solids : 15 mm

TECHNICAL DATA

- Asynchronous 2 pole motor
- Insulation class: B
- Single-phase : 220 - 240V/50Hz
- Protection degree: IP68
- Supplied with 9m cable length type H07RNF
- Pump available with float switch
- Automatic thermal overload protection for single phase version
- Discharge size : 2"



IDENTIFICATION CODE

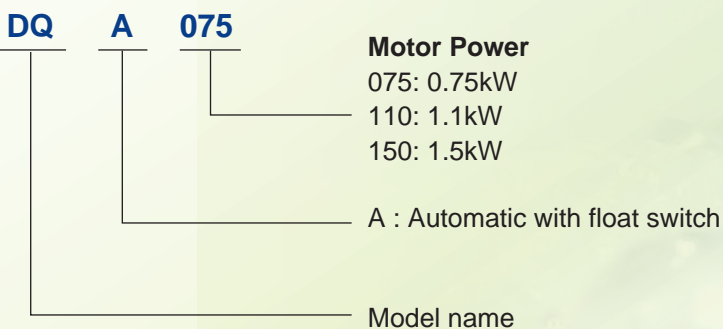

Closed Impeller

PERFORMANCE CURVE

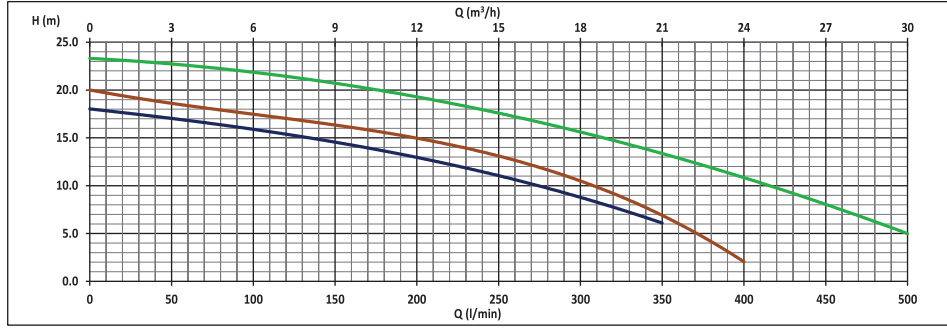

Pump Type	Power		Current A	Q = Capacity														
	kW	HP		l/min	H = Total Head													
					0	100	200	250	300	350	400	450	500					
Single-Phase 240V 50Hz				0	6	12	15	18	21	24	27	30						
DQA 075	0.75	1.0	5.5	18.0	16.0	12.8	11.0	9.0	6.0									
DQA 110	1.1	1.5	7.0	20.0	17.5	15.0	13.0	10.5	7.0	2.0								
DQA 150	1.5	2.0	8.8	23.3	21.9	19.2	17.7	15.5	13.4	10.9	8.0	5.0						

SECTIONAL VIEW

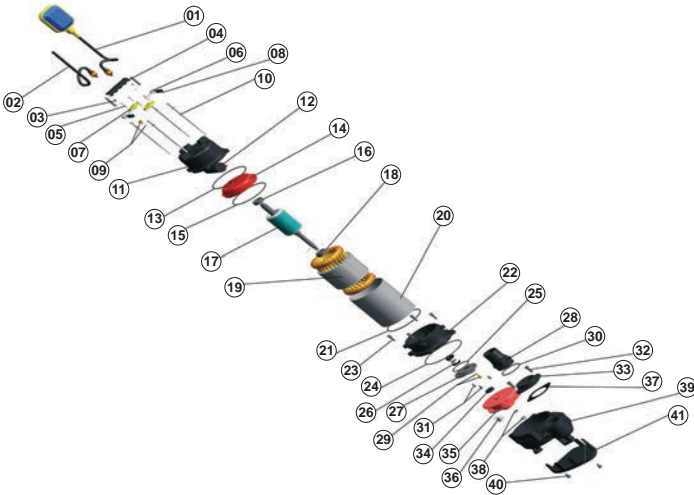

No.	Description	Qty.	No.	Description	Qty.
1	Float switch	1	22	Cylinder	1
2	Cable	1	23	Screw and shim	4
3	Screw	2	24	O-ring	1
4	Handle	1	25	O-ring	1
5	Screw	4	26	Mechanical seal	1
6	Pressure line	2	27	Cylinder cover	1
7	Spindle shaped plate	2	28	Outlet	1
8	Cable sheath	2	29	Air screw/O-ring	1
9	Air screw/O-ring	1	30	O-ring	1
10	Screw and Shim	4	31	Screw	3
11	Upper cap	1	32	Screw	2
12	Capacitor	1	33	Outlet flange	1
13	O-ring	1	34	Skeleton oil seal	1
14	Upper bearing seat	1	35	Impeller	1
15	O-ring	1	36	Key	1
16	Bearing	1	37	Spindle shaped leather pad	1
17	Rotor	1	38	Nut and shim	3
18	Bearing	1	39	Pump body	1
19	Stator coil	1	40	Screw	3
20	Stator body	1	41	The bottom seat	1
21	O-ring	1			

DIMENSION

Model	Dimension (mm)			
	H	L	B	DN
DQA 075	435	245	185	Ø50
DQA 110	450	245	185	Ø50
DQA 150	470	255	185	Ø50

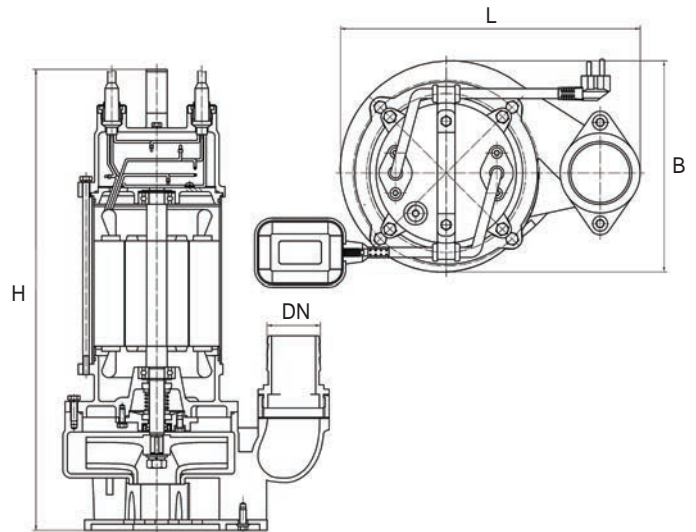

* Dimensional details are provided for reference only.
 * All specifications are subject to change without prior notice.



EBARA Pumps Malaysia Sdn Bhd
 6, Jalan TP3, UEP Subang Jaya Industrial Park,
 47620 Subang Jaya, Selangor, Malaysia.
 Tel : 03-8023 6622 Fax : 03-8023 9355
 Email : sales.epm@ebara.com
 Website : www.ebara.com.my



Authorised dealer: