



## Lifting Station

Type BEST BOX & D-TANK

*Prefabricated, robust lift stations.*

### APPLICATIONS

- **Best Box G (Garage model)**  
Lifting rainwater, from wash areas, garage downramps, etc.
- **Best Box L (Wash basin model)**  
Lifting domestic and bathroom water (basin, dishwasher, washing machine)
- **Best Box D (Shower model)**  
Particularly suited to shower water, does not need to be installed underground with the tank inlet located 90 mm from the base and a check device

### TECHNICAL DATA

#### Tank

- Model G (Garage) : High strength PVC grille
- Model L (Wash basin) : cover with overflow vent
- Model D (Shower) : cover with overflow vent
- Tank capacity : 30 litres
- Tank weight : 7 kg (BEST BOX L and BEST BOX D),  
10 kg (BEST BOX G)

#### Electric pump (selected models)

- BEST BOX G can be equipped with the BEST ONE VOX (vortex impeller) electric pump, with float switch for automatic operation
- BEST BOX L and BEST BOX D can be equipped with the BEST ONE pump with float switch for automatic operation. BEST BOX L is configured to receive water from above, while BEST BOX D receives water from below
- 5 metre cable + standardised plug
- 2800 rpm
- Single phase voltage : 230V +/- 10%
- Insulation class F
- Protection rating IP68
- Maximum fluid temperature : 50°C
- Maximum solid passage : 10 mm BEST ONE,  
20 mm BEST ONE VOX

### FEATURES

- Quick, easy installation
- Robust, compact construction
- Available with/without electric pump

### MATERIAL

#### Tank

- High density polyethylene

#### Electric pump (selected models)

- AISI 304 stainless steel construction throughout
- Mechanical seal as standard supply



BEST BOX G



BEST ONE VOX



BEST BOX D/L



BEST ONE

## PERFORMANCE CHART

(per ISO 9906 Annex A)

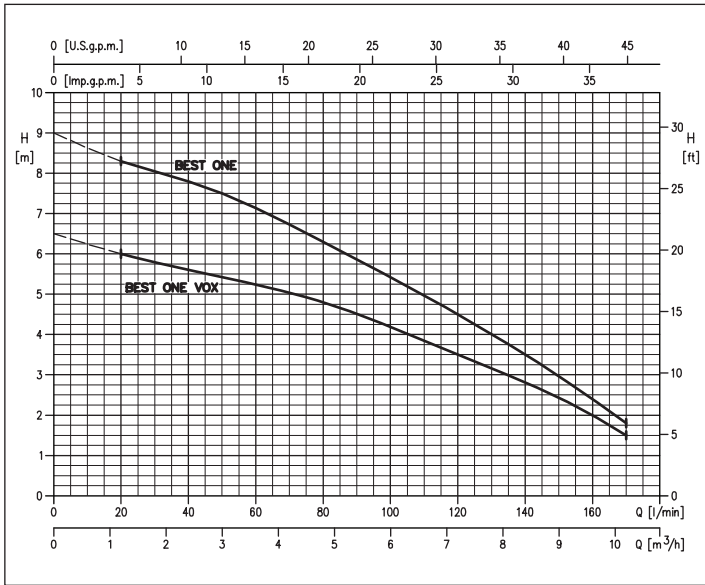

## SPECIFICATIONS

Model		BEST BOX G	BEST BOX L	BEST BOX D
Liquid Handled	Type of liquid	Dirty water, Rainwater	Water for domestic use	Water from the shower
	Max temperature [°C]	50		
	Max solids size [mm]	20	10	
Tank capacity [l]		30		
Pipe Connection	Inlet	Grid	DN 50	
	Outlet	1" ¼		
Material	Casing	High density polyethylene		
Pump kit	Type (Single-phase)	BEST ONE VOX	BEST ONE	
	Piping	1" ¼ discharge pipe		
Number of pumps that can be installed		1		

## TECHNICAL SPECIFICATIONS

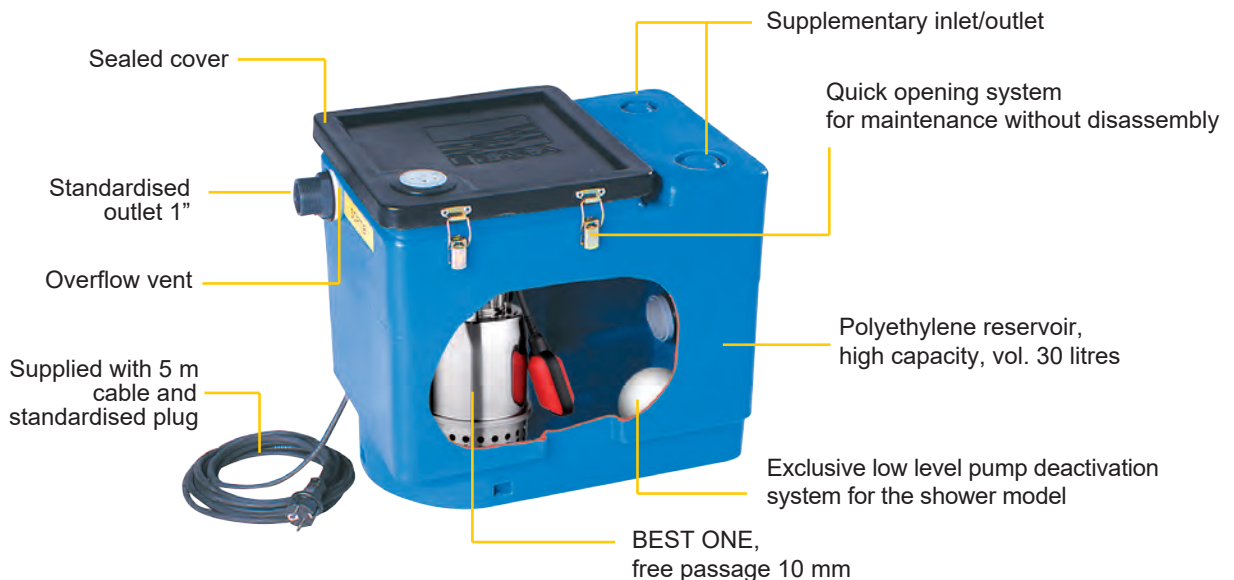
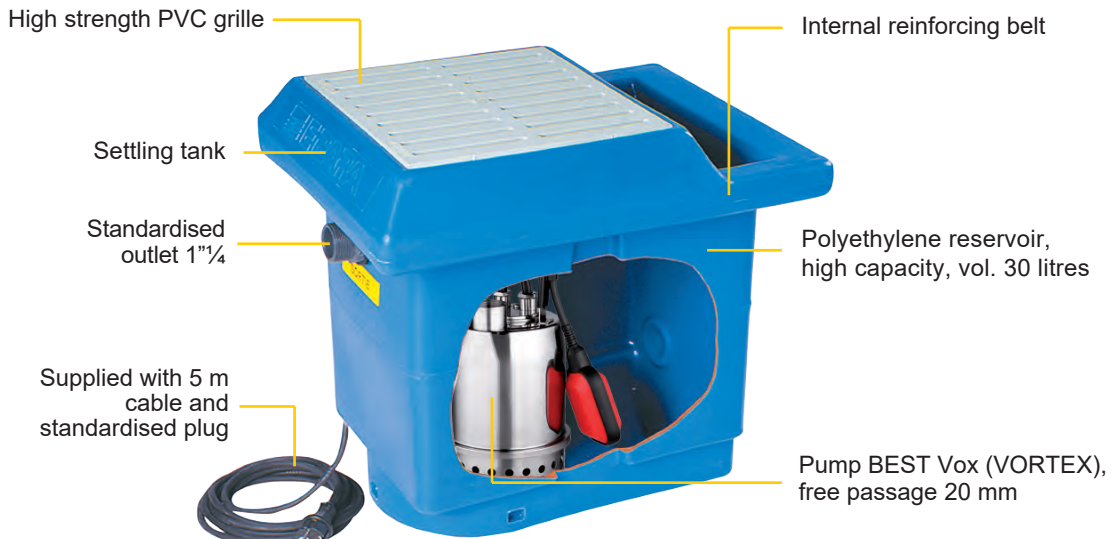

DIMENSIONS

**BEST BOX G**

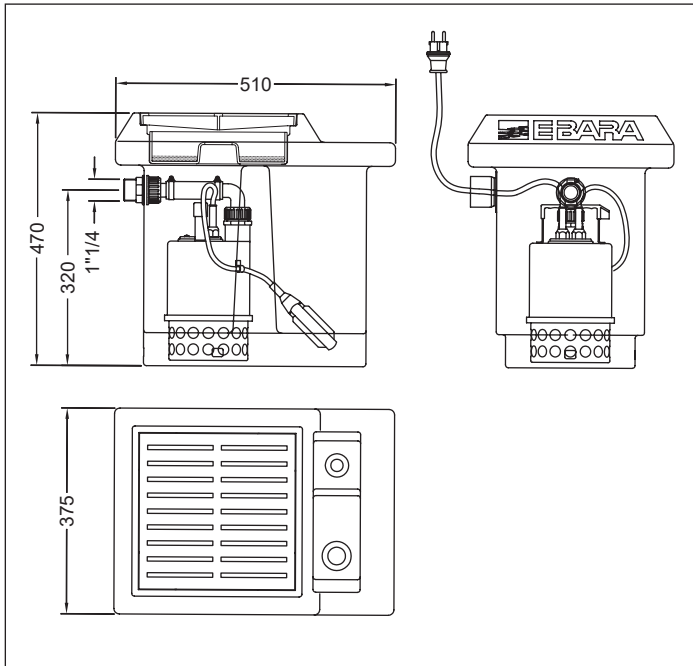

**BEST BOX L**

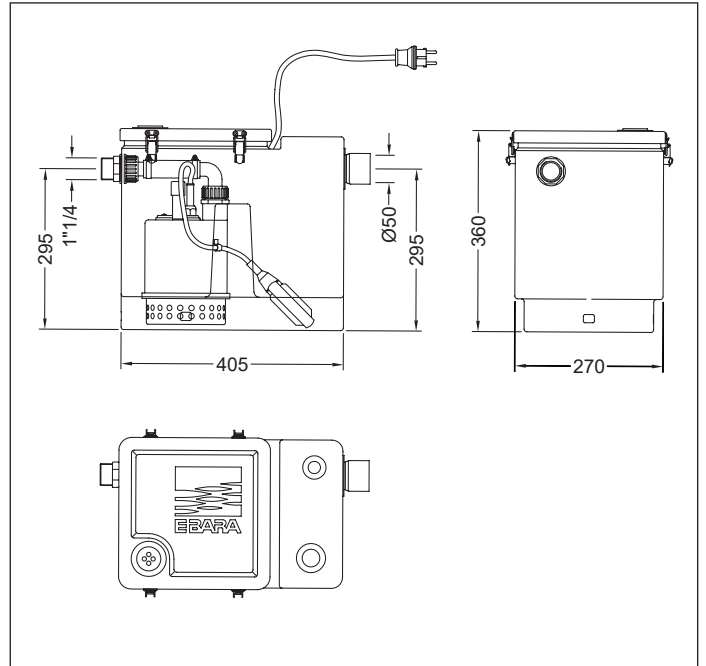

**BEST BOX D**

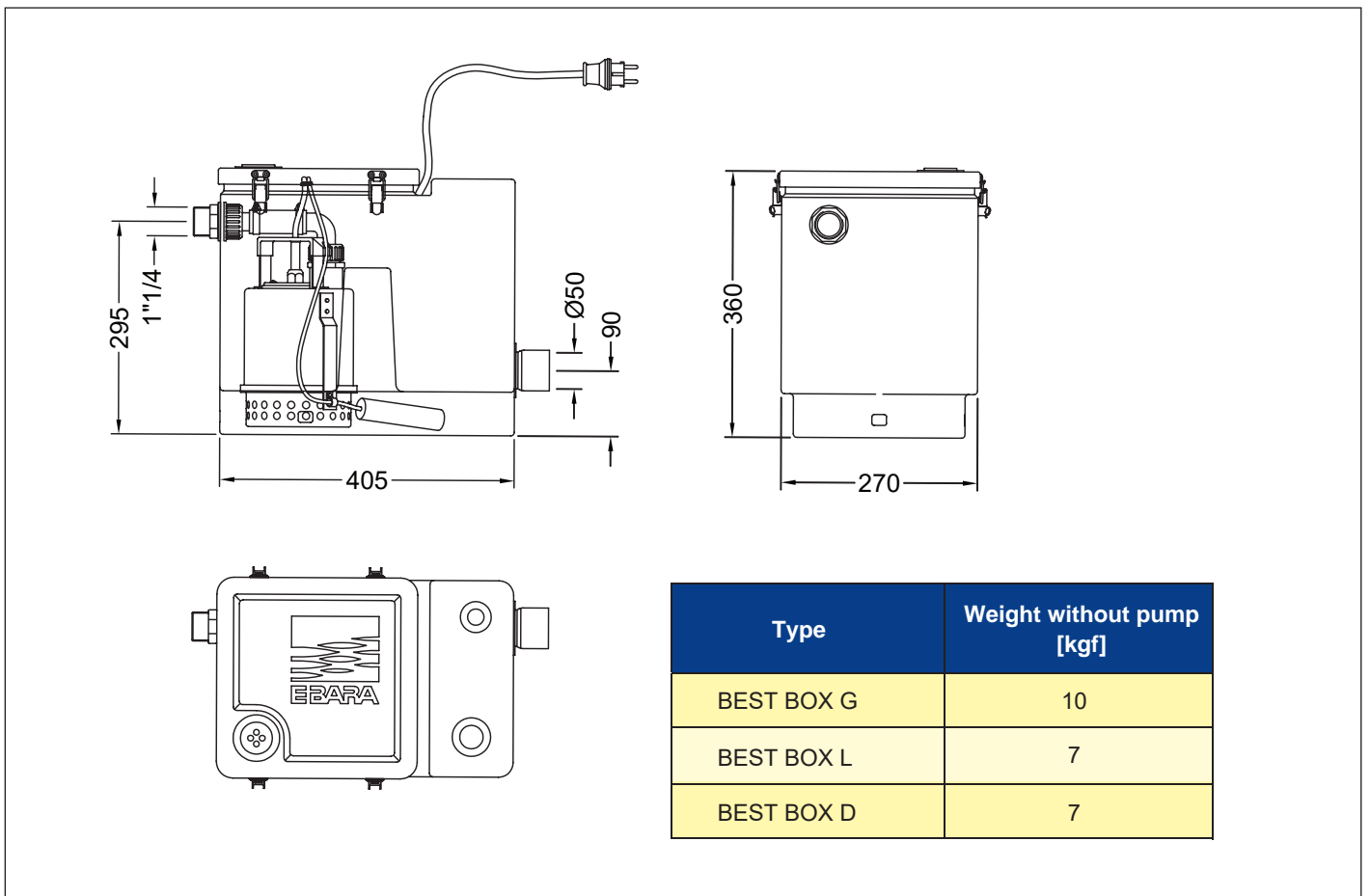

Type	Weight without pump [kgf]
BEST BOX G	10
BEST BOX L	7
BEST BOX D	7

## WASTEWATER TANKS



**D-TANK 100**



**D-TANK 200**



**D-TANK 600**



## TECHNICAL FEATURES

- Sturdy construction
- Easy installation
- Equipped with rapid flow elbow (D-TANK 200-600)

## TECHNICAL DATA

- TANK made of polyethylene, capacity 100 liters, 200 liters and 600 liters, inclusive of cover with expanded EPDM seal
- Inlet : DN 110 with seal
- Outlet - DN 50 with seal (D-TANK 100)  
- DN 63 with seal (D-TANK 200-600)
- Power supply : - 3 x M20 cable glands + 2 closing caps (for D-TANK 100)  
- 4 x M20 cable glands + 3 closing caps (for D-TANK 200)  
- 6 x M20 cable glands + 4 closing caps (for D-TANK 600)

## AVAILABLE VERSIONS

### Basic version

- **D-TANK 100**  
100l TANK with seal and cable glands
- **D-TANK 200 (fig.1)**  
200l TANK (Ø 2" x 63 mm PVC flow pipe, 2 pipe support clamps, vertical outlet with elbow)
- **D-TANK 600 (fig.1)**  
600l TANK (Ø 2" x 63 mm PVC flow pipe, 3 pipe support clamps, vertical outlet with elbow)

### Version "E"

- **D-TANK 100E (fig.1)**  
100l TANK (Ø 1 1/2" x 50 mm PVC flow pipe, 2 pipe support clamps, vertical discharge with bend)
- **D-TANK 200E (fig.2)**  
200l TANK + pre-assembled coupling kit with guide pipes (Ø 2" x 63 mm PVC flow pipe, 2 pipe support clamps, vertical outlet with elbow, base plate supporting weight up to 40 kg)
- **D-TANK 600E (fig.2)**  
600l TANK + pre-assembled coupling kit with guide pipes (Ø 2" x 63 mm PVC flow pipe, 3 pipe support clamps, vertical outlet with elbow, base plate supporting weight up to 40 kg)



(fig.1)



(fig.2)

## SPECIFICATIONS

MODEL		D-TANK 100	D-TANK 200	D-TANK 600
Liquid Handled	Type of liquid	Water for domestic use		
	Max temperature [°C]	60		
Tank capacity [l]		100	200	600
Pipe Connection	Inlet	DN 110		
	Outlet	DN50	DN63	
Material	Casing Gaskets Piping	Polyethylene EPDM (cover), NBR PVC		
Kit included	D-TANK	Bend, Pipes in bag (double in D-TANK 600)		
	D-TANK E (equipped)	Coupling foot (1,5"-2" GAS)-Bend-Pipes(double in D-TANK 600)		
Number of pumps that can be installed		1		2
Standard compliance		UNI-EN 12050 - 2		
Note		D-TANK 200 (E) / D-TANK 600 (E) LOAD UP TO 40kgf		

## DIMENSION AND WEIGHT

### D-TANK 100 / 100 E

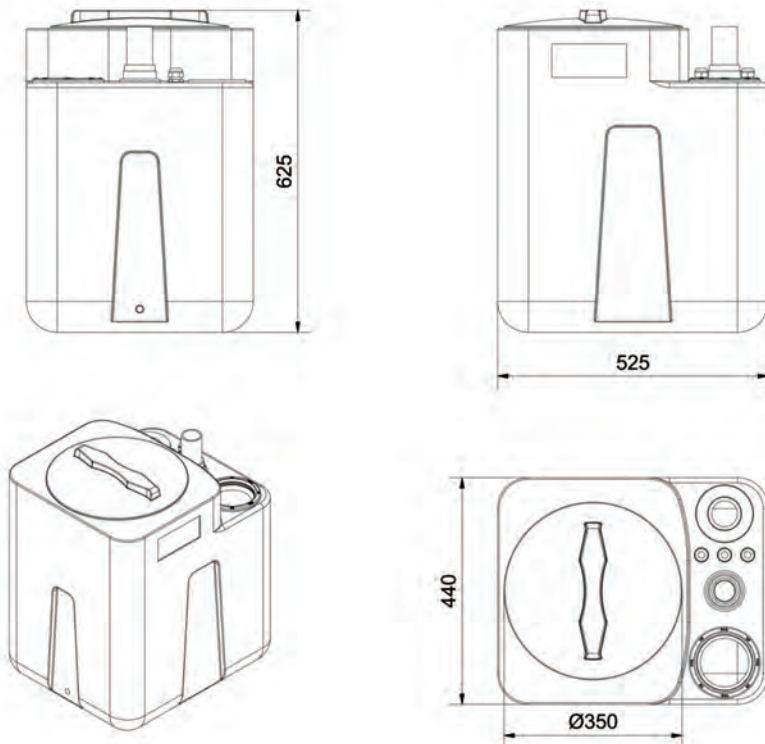

Type	Weight [kg]
D - TANK 100	9.2
D - TANK 100 E	9.5

DIMENSION AND WEIGHT

**D-TANK 200 / 200 E**

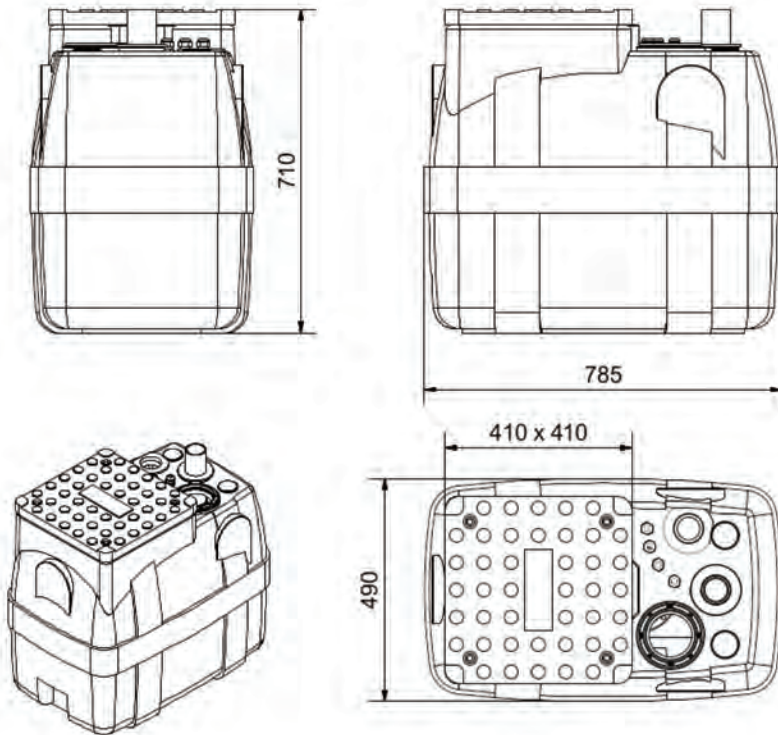

Type	Weight [kg]
D – TANK 200	13
D – TANK 200 E	23

**D-TANK 600 / 600 E**

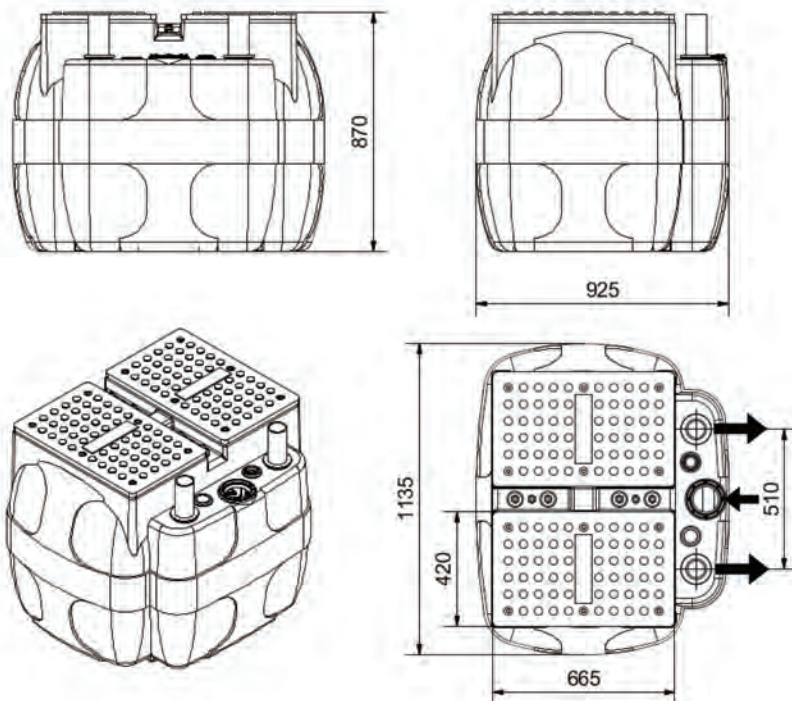

Type	Weight [kg]
D – TANK 600	33
D – TANK 600 E	53

\* Dimensional details are provided for reference only.  
 \* All specifications are subject to change without prior notice.



**EBARA Pumps Malaysia Sdn Bhd**  
 6, Jalan TP3, UEP Subang Jaya Industrial Park,  
 47620 Subang Jaya, Selangor, Malaysia.  
 Tel : 03-8023 6622 Fax : 03-8023 9355  
 Email : sales.epm@ebara.com  
 Website : www.ebara.com.my



Authorised dealer: