



## **Automatic Booster Unit - Compact Booster** Type AM - PT

### APPLICATIONS

Horizontal centrifugal multistage pumps suitable for pressure boosting systems, car washing, small garden irrigation and general clean water pumping.

### FEATURES

- **Fully tested & assembled unit**  
Ensure trouble-free operation.
- **Stainless steel pump set used**  
Hygiene and corrosion-free water.
- **EBARA 1-year warranty on all components used**  
More value for money.
- **Quiet operation**  
Good and enjoyable pressure expected.
- **Nationwide Dealers representation**  
After-sale services assurance.

### TECHNICAL DATA

- Asynchronous 2 pole motor
- Insulation: Class F
- Protection degree: IP44
- 1~230V  $\pm$  10% 50Hz, 3~230/400V  $\pm$  10% 50Hz
- Permanent split capacitor and automatic thermal overload protection for single-phase version
- Thermal protection to be provided by the user for three-phase version



MODEL	kW	*Application	l/min m <sup>3</sup> /h	20	30	40	50	60	80	Connection
				Head in m	30.7	28.2	25.2	21.8	18	
Compact Booster AM 6-PT	0.4									1" x 1"
Compact Booster AM 8-PT	0.6									1" x 1"

\*For guidance only

DIMENSION

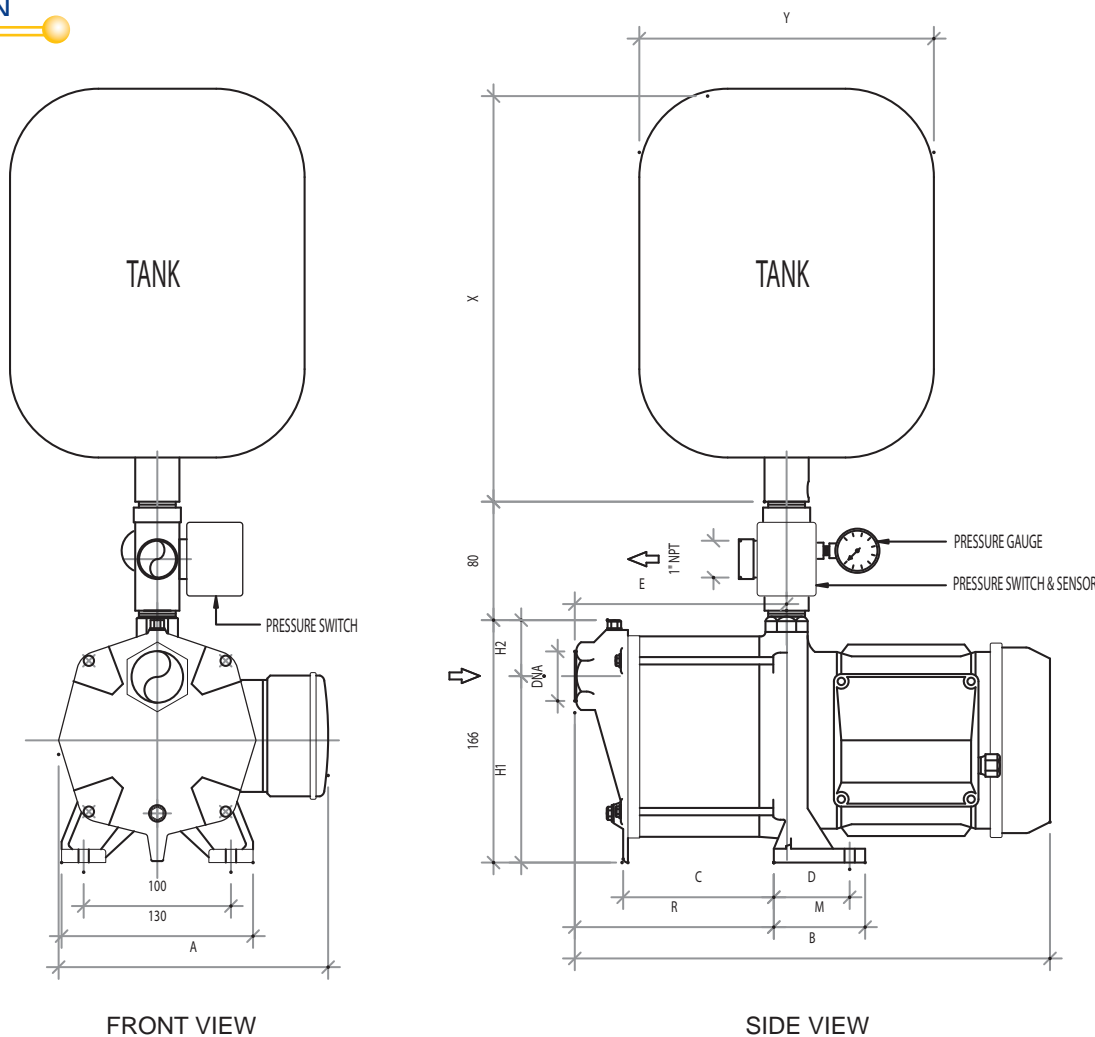

Pumps Type	kW	Dimensions (mm)											DNA	
		A	B	C	D	E	H1	H2	M	R	X	Y		Tank (Lit)
Single Phase	1~													
COMPACT AM 6-PT	0.4	183.5	333.3	108	51.5	146.5	127.5	38.5	62	146.5	317	203	8	1" NPT
COMPACT AM 8-PT	0.6	183.5	359.5	134	51.5	172.5	127.5	38.5	62	172.5	370	275	18	1" NPT

\* Dimensional details are provided for reference only.  
 \* All specifications are subject to change without prior notice.



**EBARA Pumps Malaysia Sdn Bhd**  
 6, Jalan TP3, UEP Subang Jaya Industrial Park,  
 47620 Subang Jaya, Selangor, Malaysia.  
 Tel : 03-8023 6622 Fax : 03-8023 9355  
 Email : sales.epm@ebara.com  
 Website : www.ebara.com.my



Authorised dealer: